



HS-169 Single Frequency Oscillator 26.5625MHz

Description

The **HS-169** crystal oscillator is designed to support the Tachyon™ clocking requirements at 26.5625MHz.

Features

- Meets HP TACHYON™ Clock Generator
- Will withstand vapor phase temperatures of 253°C for 4 minutes maximum
- Space-saving alternative to discrete component oscillators
- High shock resistance, to 3000g
- All metal, resistance weld, hermetically sealed package
- Low Jitter
- High Q Crystal actively tuned oscillator circuit
- Power supply decoupling internal
- No internal PLL avoids cascading PLL problems
- Gold plated leads - Solder dipped leads available upon request
- Low power consumption
- RoHS Compliant, Lead Free Construction (unless solder dipped leads are supplied)
- COTS/Dual use

Electrical Connection

Pin	Connection
1	N.C.
7	Grd & Case
8	Output
14	V _{CC}

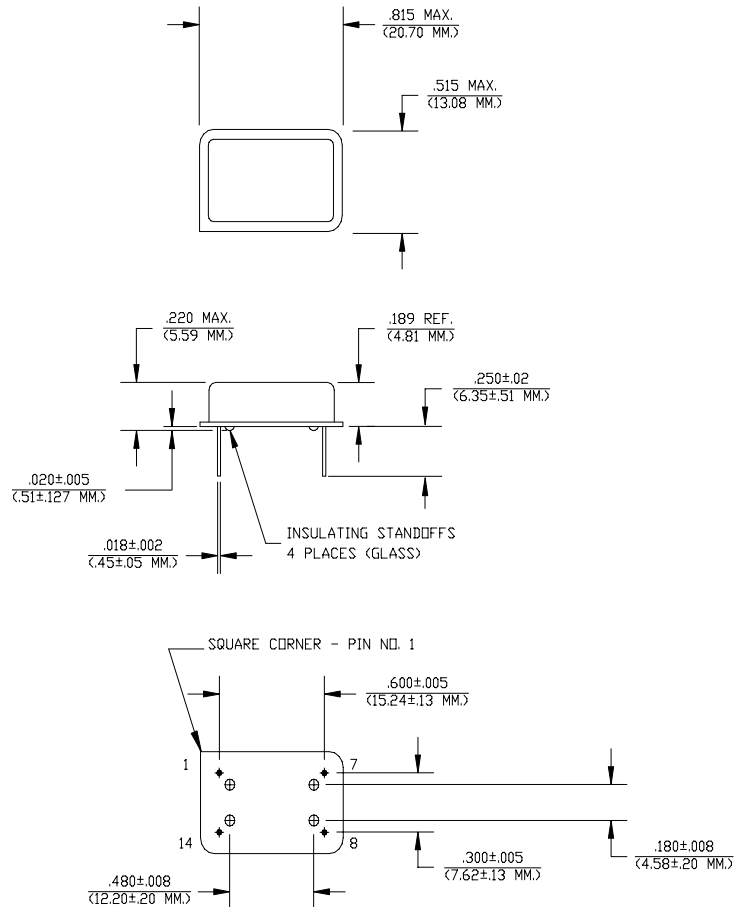

HS-169 Continued Single Frequency Oscillator 26.5625MHz

Rev. K

Operating Conditions and Output Characteristics

Electrical Characteristics

Parameter	Symbol	Conditions	Min	Typical	Max
Duty Cycle	-----	@ $V_{CC}/2$	40/60%	-----	60/40%
Logic 0	V_{OL}	@ 16mA	-----	0.3V	0.4V
Logic 1	V_{OH}	@ 0.4mA	2.4V	4.0V	-----
Rise & Fall Time	tr,tf	@ 0.4 to 2.4V	-----	-----	2.8 ns
Jitter, RMS ⁽¹⁾	-----	-----	-----	-----	5 psec
Frequency Stability	dF/F	Overall conditions including: voltage, calibration, temp., 20 yr aging, shock, vibration	-100ppm	-----	+100ppm

General Characteristics

Parameter	Symbol	Conditions	Min	Typical	Max
Supply Voltage	V_{CC}	-----	4.75V	5.0V	5.25V
Supply Current	I_{CC}	No Load	0.0 mA	-----	60 mA
Output current	I_O	-----	0.0 mA	-----	±25.0 mA
Operating temperature	T_A	-----	0°C	-----	70°C
Storage temperature	T_S	-----	-55°C	-----	125°C
Power Dissipation	P_D	-----	-----	-----	315 mW
Lead temperature	T_L	Soldering, 10 sec.	-----	-----	300°C
Load	-----	-----	-----	-----	10 TTL gate
Start-up Time	t_s	-----	-----	-----	3 ms

Environmental and Mechanical Characteristics

Mechanical Shock	Per MIL-STD-202, Method 213, Condition E
Thermal Shock	Per MIL-STD-883, Method 1011, Condition A
Vibration	0.060" double amplitude 10 Hz to 55 Hz, 35g's 55Hz to 2000 Hz
Soldering Condition	300°C for 10 seconds
Hermetic Seal	Leak rate less than 1×10^{-8} atm.cc/sec of helium

Footnotes:

- 1) Jitter performance is frequency dependent. Please contact factory for full characterization.
RMS jitter bandwidth of 12kHz to 20MHz.

Test Load:

